



Arlink 7000 Workstation

Instructions for Assembly

Basic Bench Assembly
Undersurface Accessories
Above Surface Accessories
VSI Mounting Instructions

Making Workspace Work® is a trademark of Lista International Corporation.

Creation Date	Document Number	Rev	Description
Feb/01/06	AS70007	B	Arlink 7000 Workstation

This manual is proprietary information of Lista International Corporation. Unauthorized reproduction of any portion of the manual is prohibited without consent of Lista International Corporation. The material in this manual is for informational purposes only. It is subject to change without notice. Lista International Corporation assumes no responsibility for any typographical errors contained in the manual.

© 2006 by Lista International Corporation, all rights reserved.
106 Lowland Street
Holliston, MA 01746-2094
E-mail: sales@listaintl.com

All rights reserved.

For questions or technical support, call 1-800-722-3020
ISO 9001 Certified

Table of Contents

Basic Bench Assembly Step 1	3
Basic Bench Assembly Step 2.....	3
Basic Bench Assembly Step 3.....	3
Basic Bench Assembly Step 4.....	3
Back & End Stops	4
Rear & End Modesty Panels	4
Footrest.....	4
Drawer Installation.....	4
Powerbeam Installation	5
Riser Shelf—Box Style	5
Riser Shelf—Column Style.....	5
VSI-8 Vertical Space Integrator	5

Arlink 7000

Assembly Instructions

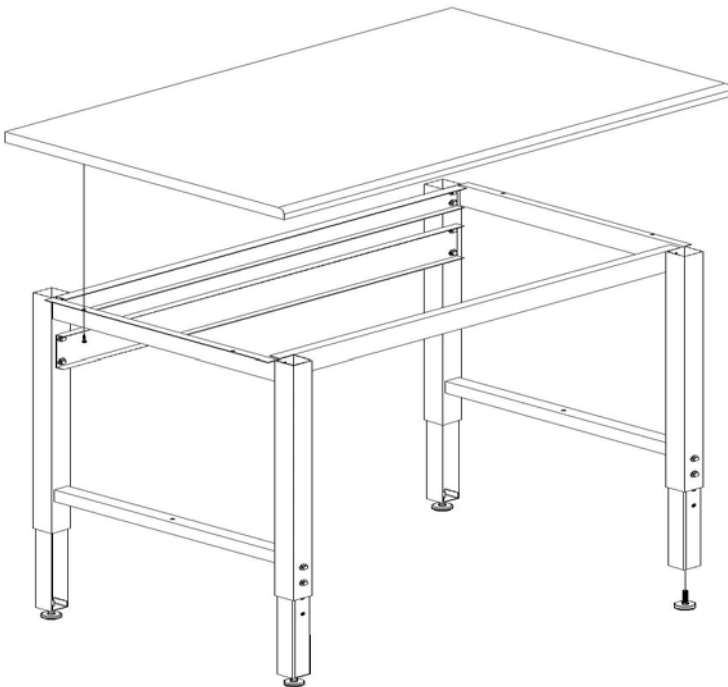
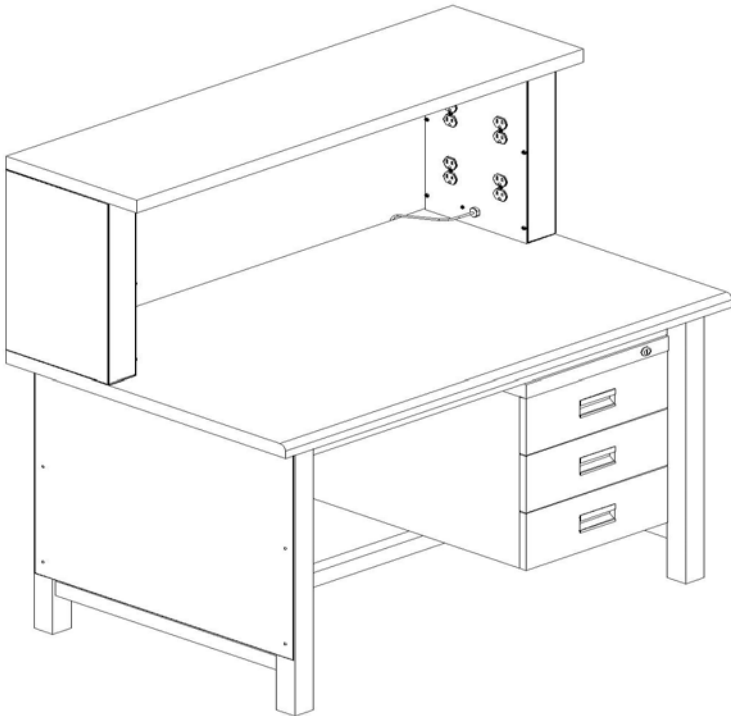

Basic Bench Assembly

Step 1

Install adjustable glides into inserts in the bottom of the leg extenders.

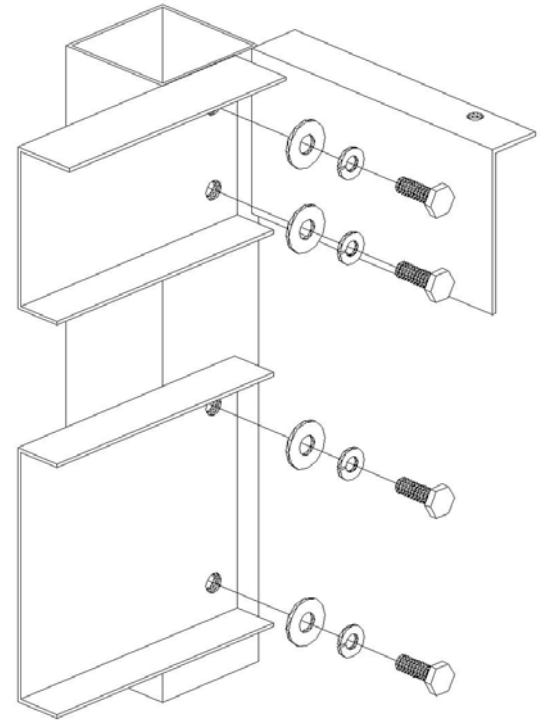

Step 2

Assemble frame by attaching load beams and stiffener to legs using the 1/4"-20 x 3/4" hex bolts 1/4" flat washers and 1/4" lock washers included. Leave bolts loose until all are in place, then square up the frame and tighten bolts. **Note: One flange on each load beam has holes used to secure the worksurface. Ensure the holes are at the top of the frame.**

Step 3

Invert worksurface onto soft, clean surface to avoid damage to laminate.

Step 4

Invert assembled frame onto the underside of the worksurface. Ensure stiffener is located at the rear of the worksurface. (Square edge). Center the frame on the worksurface. Fasten frame to the worksurface through the holes in the load beams and leg flanges using the #10 x 1" wood screws provided.

Back & End Stops (Optional)

Back and end stops are pre-punched for easy installation. After worksurface has been mounted on frame, fasten stops to back and sides of worksurface with the #10 x 1" wood screws provided.

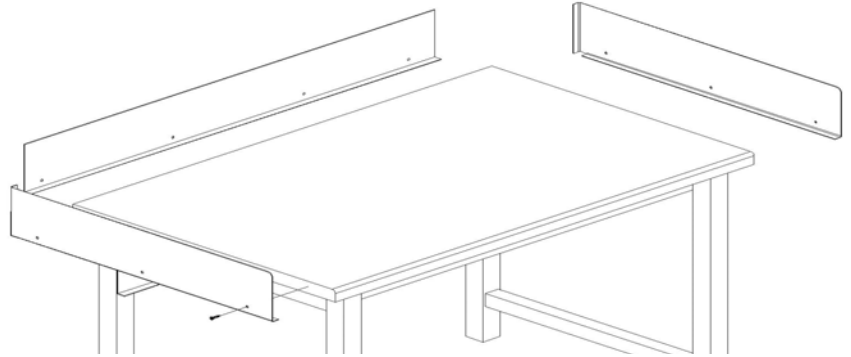

Rear & end Modesty Panels (Optional)

Fasten all 3 panels to leg frame using the #8 x 3/4" self-drilling screws provided.

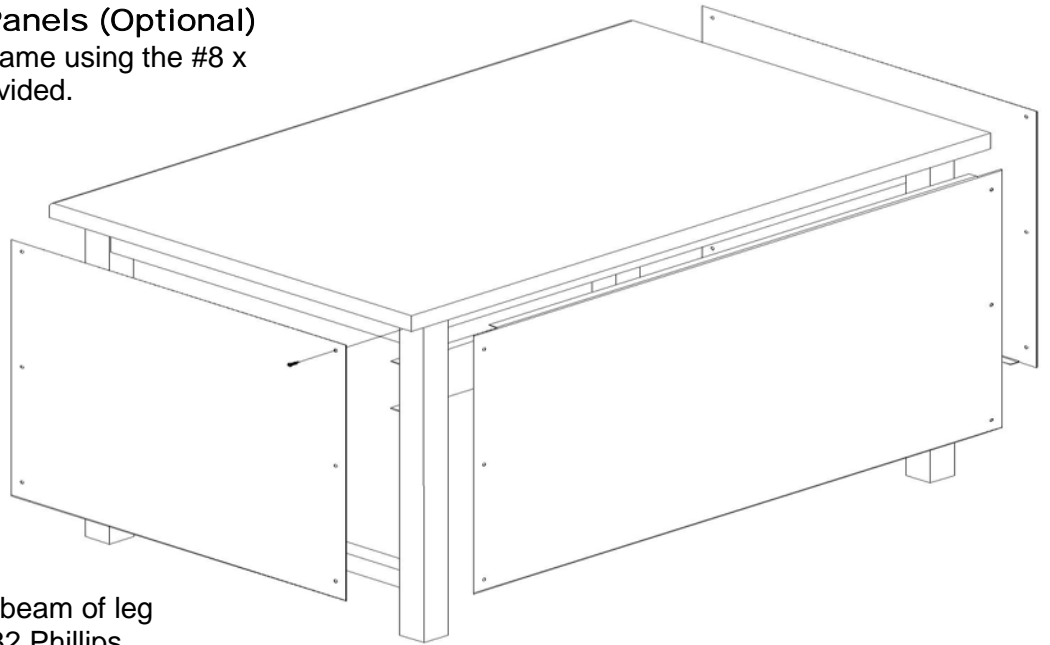

Footrest (Optional)

Fasten footrest into crossbeam of leg assembly using the #10-32 Phillips machine screws provided.

Hangers for 30" deep workbench are shown. Hangers for 36" deep workbench are approximately 6" longer, while the drawer mounts in the same position.

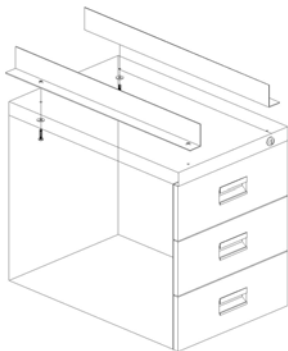
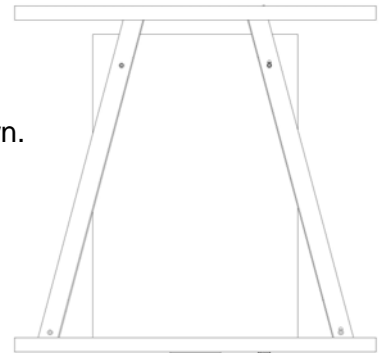

Drawer Installation (Optional)

For ease of assembly the drawers can be removed by releasing the disconnects on both sides of the slides and pulling the drawer forward to separate the slides. Using 1/4"-20 x 1" machine screws loosely fasten "L" shaped hangers to the rear of the drawer. Swing the front of the hangers away to form a "V". Lift drawer into position. Set drawer hangers on rear load beam flange. Swing the front of the hangers back in, and rest them on the front load beam. Fasten the drawer to the front of the hangers, slide into position along the length of the

Power Beam Installation (Optional)

Position Power Beam where desired on top or underside of worksurface. **Note on Static Dissipative worksurfaces install insulating washers provided between power beam and worksurface. Use power beam as template and drill 5/16" diameter x 5/16" deep holes for insulators. ***Read Warning Box Page 4.** Fasten to bench with the #10 x 1" wood screws provided.

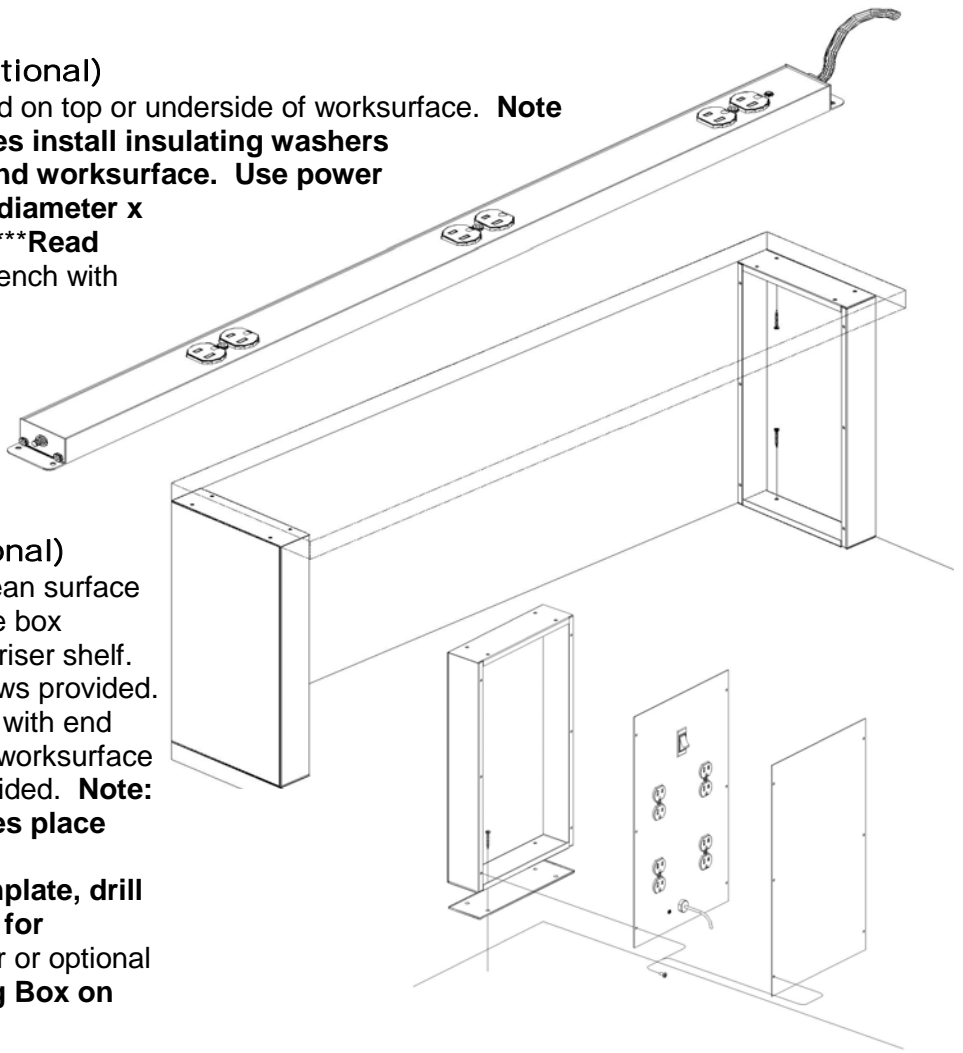

Riser Shelf—Box Style (Optional)

Invert instrument shelf onto soft, clean surface to avoid damage to laminate. Place box supports flush with end and rear of riser shelf. Fasten with the #10 x 1" wood screws provided. Invert shelf and boxes. Place flush with end and rear of worksurface. Screw to worksurface with the #10 x 1" wood screws provided. **Note: On static dissipative worksurfaces place insulator between riser box and worksurface. Using box as a template, drill 5/16 diameter X 5/16" deep holes for insulator.** Install box support cover or optional electrical panels. *****Read Warning Box on Page 4.**

Riser Shelf—Column Style (Optional)

This system requires drilling four 3/8" diameter holes, on 36", 48" or 60" centers, depending on the module size required. The "J" bolts provided hook over the embosses in the center of the columns. Place the mounting plate under the column and mount to worksurface using the 5/16"-18 lock nuts, 5/16" flat washers provided. Align rear of shelf with rear of top mounting plate. Fasten riser shelf through holes in the plate using wood screws provided. **Note: On Static Dissipative worksurfaces place insulator between mounting plate and worksurface. ***Read Warning Box on Page 4**

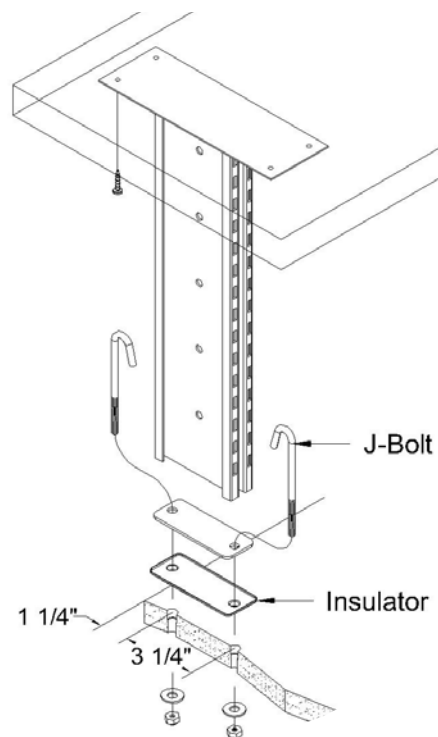

Note: Prior to drilling bench tops ensure that there will not be interference with any undersurface components.

VSI-8 Vertical Space Integrator (Optional)

Position the mounting plates of the columns on the worksurface approximately 3/4" from the rear of the surface. Using the modesty panel as a guide, centre the columns horizontally on 36", 48", 60", or 72" centers as required. Using the mounting plates as templates, mark and drill eight 5/16" diameter holes. Using the 1/4"-20 bolts, washers and lock nuts provided install the columns as shown. Do not tighten the hardware until the modesty panel is installed. **Note: On Static Dissipative worksurfaces place insulator between mounting plate and worksurface. ***Read Warning Box Below.**

Note: Prior to drilling bench tops ensure that there will not be interference with any undersurface components.

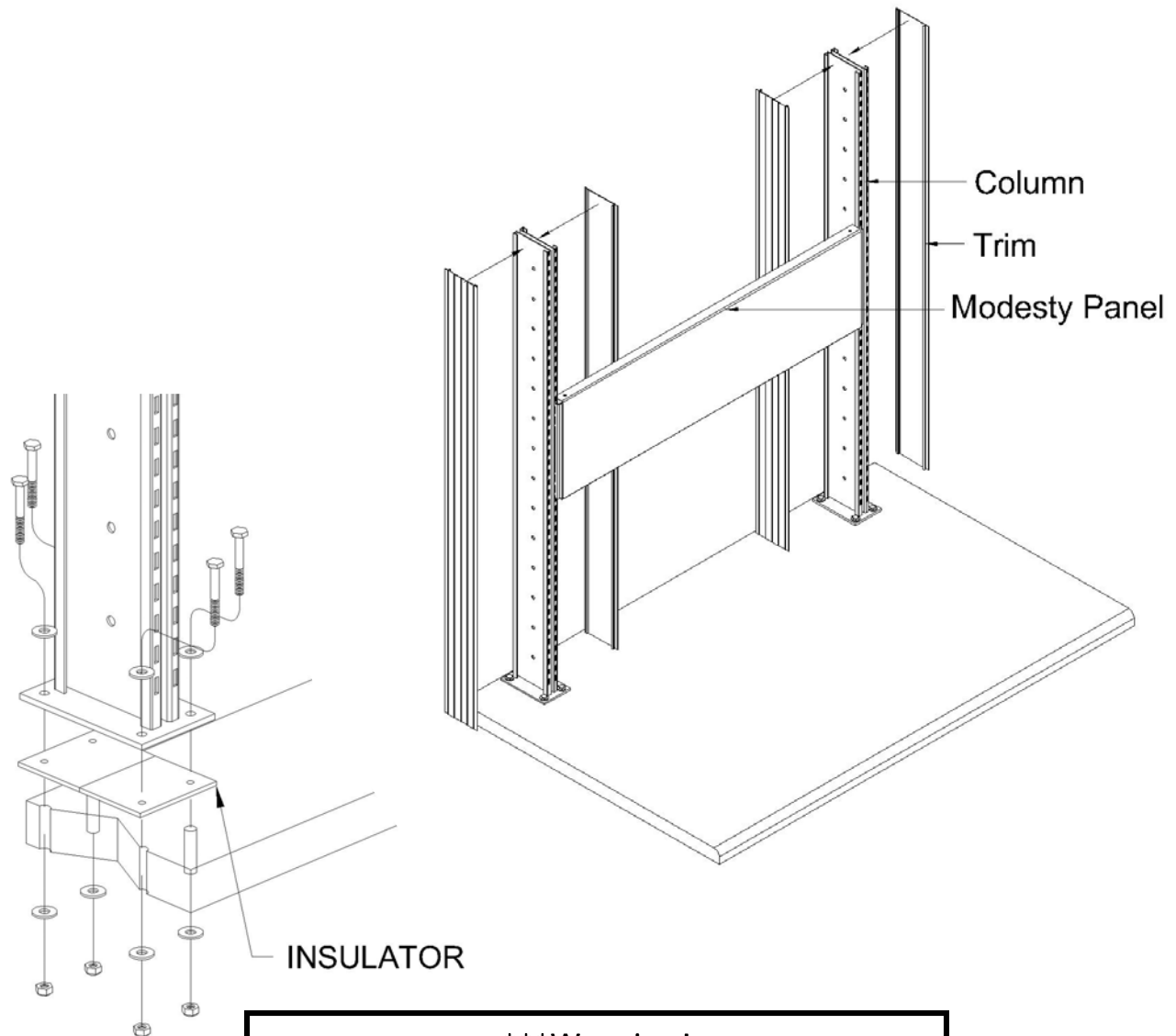

*****Warning!**
Failure to comply with the proper installation of insulating grommets or gaskets may result in hazardous electrical conditions for personnel. The ultimate responsibility for personnel safety lies with the end user.

Document Number: AS70007

Print Date: May, 2006

This manual is proprietary information of Lista International Corporation. Unauthorized reproduction of any portion of this manual is prohibited without written consent of Lista International Corporation. The material in this manual is for informational purposes only. It is subject to change without notice. Lista International Corporation assumes no responsibility for any typographical errors contained in this manual.

©2006 by Lista International Corporation
106 Lowland Street
Holliston, MA 01746-2095

All rights reserved.



Lista International Corporation
106 Lowland Street
Holliston, MA 01746 USA
Telephone: (800) 722-3020
Fax: (508) 626-0353
sales@listaintl.com
www.listaintl.com